

SERIES 329

OUTSIDE MICROMETER WITH EXTENSION ANVIL

- ◆ Adjust collars for different measuring ranges
- ◆ Graduation 0.01mm
- ◆ Ratchet stop
- ◆ Carbide measuring faces
- ◆ Supplied with setting standards

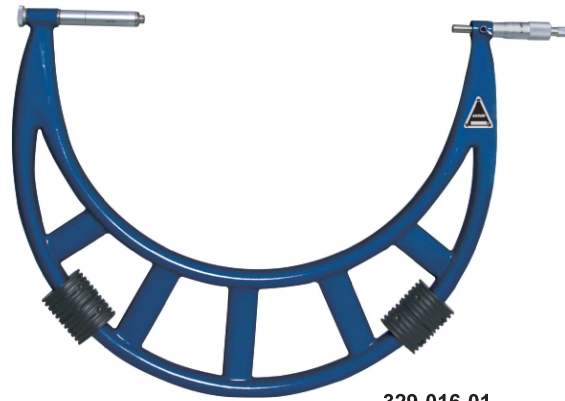

329-016-01

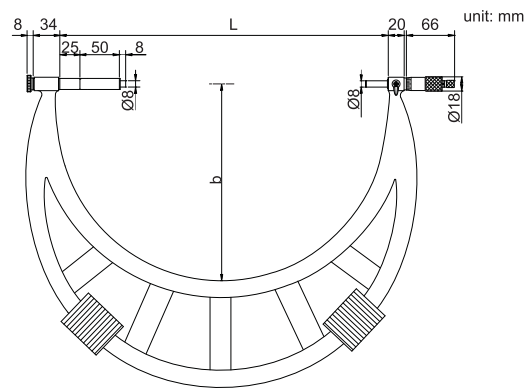

Code	Range	Accuracy	L	b
329-016-01	300-400mm	11μm	410	250
329-020-01	400-500mm	13μm	510	295
329-024-01	500-600mm	14μm	610	345
329-028-01	600-700mm	16μm	710	395
329-032-01	700-800mm	18μm	810	445
329-036-01	800-900mm	20μm	910	495
329-040-01	900-1000mm	22μm	1010	545

SERIES 316

DIGITAL BLADE MICROMETER

- ◆ Measure the groove diameter of shafts and keyways
- ◆ Quick measurement with lever
- ◆ Resolution: 0.001mm/0.00005"
- ◆ IP65 protection level
- ◆ Button: on/off, mm/inch, origin, ABS/zero
- ◆ Automatic power off
- ◆ Data output (cable code: 100-13)
- ◆ Carbide measuring faces
- ◆ Setting standards are included (except 316-001-03)



316-001-03

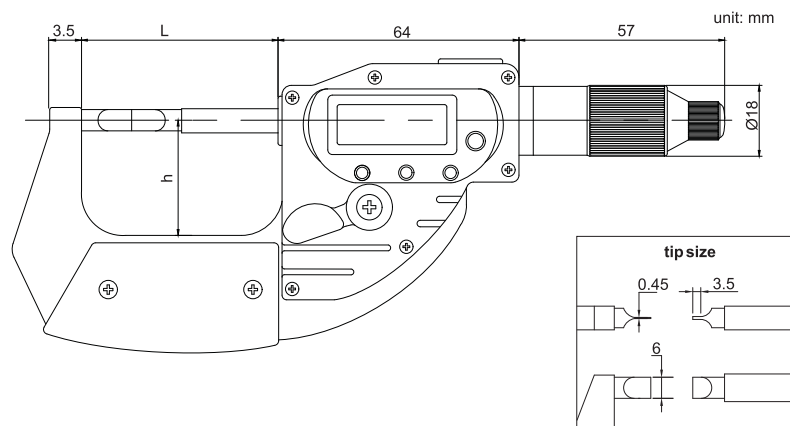

Code	Range	Accuracy	h	L
316-001-03	0-25mm/0-1"	3μm	31	55
316-002-03	25-50mm/1-2"	3μm	44	80
316-003-03	50-75mm/2-3"	4μm	58	115