

SERIES 328

SPLINE MICROMETER

- ◆ Measure grooves and sharped parts
- ◆ Graduation: 0.01mm
- ◆ Carbide measuring faces
- ◆ Ratchet stop
- ◆ Setting standards are included (except 0-25mm)



328-001-01

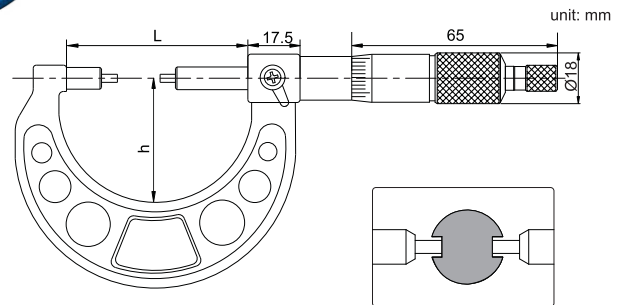

Code	Range	Anvil	Accuracy	h	L
328-001-02	0-25mm	A	4μm	39	58
328-001-01	0-25mm	B	4μm	39	58
328-002-01	25-50mm	B	4μm	53	83
328-003-01	50-75mm	B	5μm	65	109
328-004-01	75-100mm	B	5μm	76	133

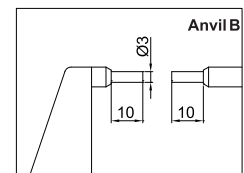
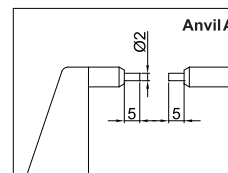

SERIES 342

DISK MICROMETER

- ◆ Measure root tangent length of gear
- ◆ Graduation 0.01mm
- ◆ Ratchet stop
- ◆ Supplied with setting standards (except 0-25mm)



342-002-02

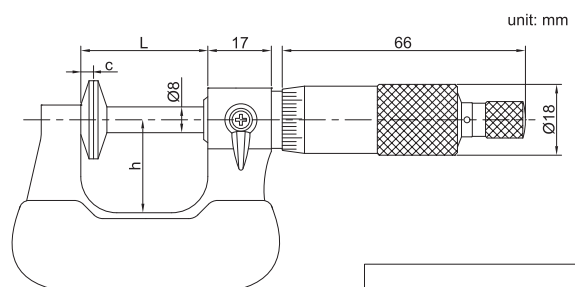

Code	Range	Accuracy	L	h	c
342-001-02	0-25mm	4μm	34	24	3.3
342-002-02	25-50mm	4μm	59	32	3.3
342-003-02	50-75mm	5μm	85	45	3.3
342-004-02	75-100mm	5μm	110	57	3.3

