

ALESAMETRI MILLESIMALI

251

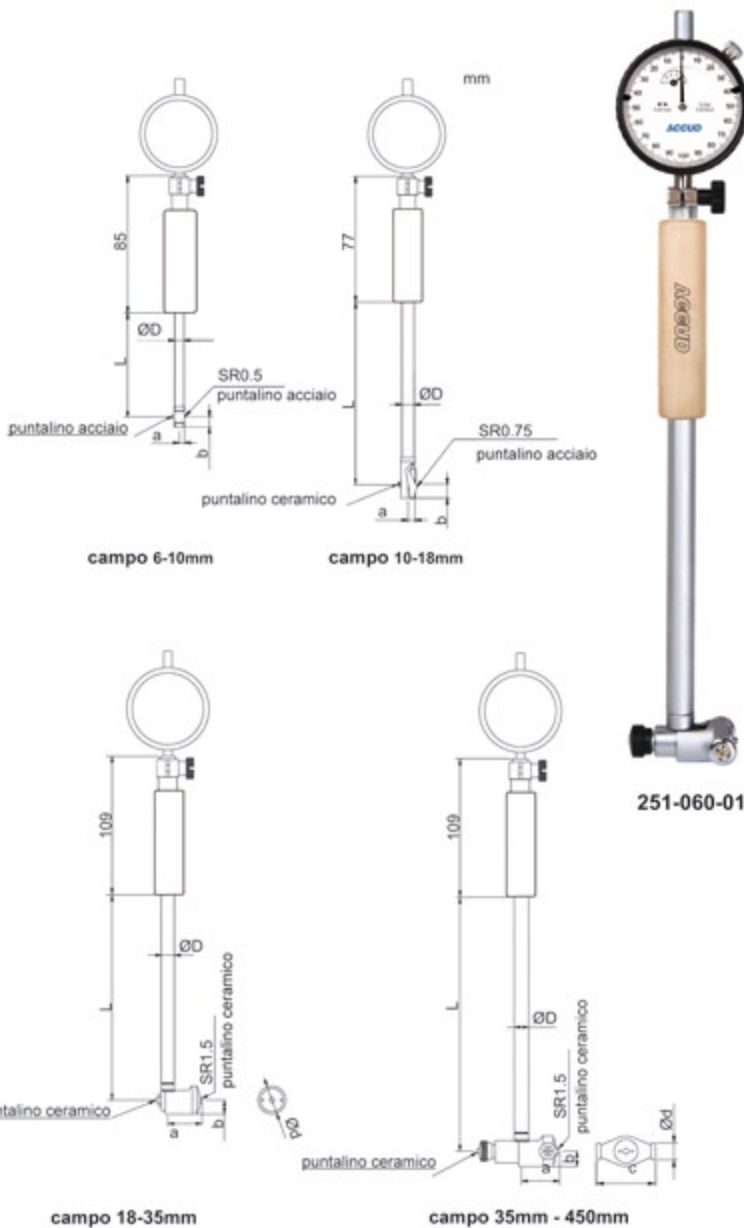

- Impugnatura isolante in legno
- Lettura 0,001mm
- Comparatore con corsa 1mm
- Anelli riscontro (su richiesta)



Codice	Campo	Comparatore	Precisione	Ripetibilità	a	b	c	Ød	ØD	e	L
251-010-01	6-10mm	Corsa: 1mm Lettura: 0,001mm	±0.012mm	3µm	3.6	5.7	/	/	4.5	SR1	48
251-018-01	10-18mm		±0.012mm	3µm	5.6	7.8	/	/	6	SR1	105
251-035-01	18-35mm		±0.015mm	3µm	12.2	6.4	/	12.7	9	SR1	141
251-060-01	35-60mm		±0.018mm	3µm	12.2	6.4	27	13	12.8	SR2	141
251-160-01	50-160mm		±0.018mm	3µm	26	9	27	13	12.8	SR2	141
251-250-01	160-250mm		±0.018mm	3µm	56.5	13	74.5	15	12.8	SR2	241
251-450-01	250-450mm		±0.018mm	3µm	86.5	15	101.5	15	14.5	SR2.5	241

