

## 993

## CALIBRI PER CENTRI PARTI CILINDRICHE

- Ideali per trovare centro su parti cilindriche
- Struttura in acciaio inox
- Scala con cromatura opaca



993-004-01

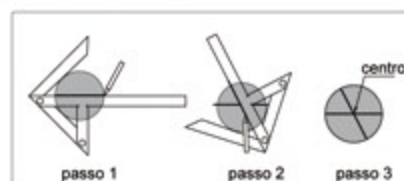
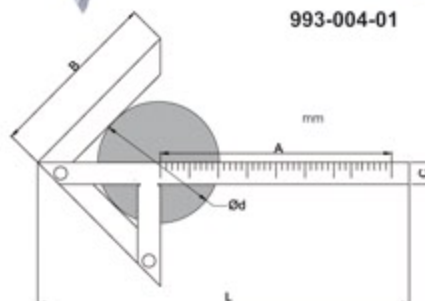

Codice	A x B	Diametro Ød	Precisione	C	L
993-004-01	100x70mm	4 - 90mm	±0.15mm	12	153
993-006-01	150x130mm	4 - 190mm	±0.15mm	15	245
993-008-01	200x150mm	6 - 220mm	±0.15mm	15	310

## 994

## RIGHE A FILO

- Smusso per controllo linearità
- DIN874
- Struttura in acciaio inox



994-002-01



Codice	L	Linearità	W	H
994-002-01	50mm	2.2µm	5	20
994-003-01	75mm	2.3µm	5	25
994-004-01	100mm	2.4µm	5	25
994-005-01	125mm	2.5µm	5	25
994-006-01	150mm	2.6µm	6	30
994-008-01	200mm	2.8µm	6	30
994-010-01	250mm	3.0µm	8	40
994-012-01	300mm	3.2µm	8	40
994-016-01	400mm	3.6µm	10	50
994-020-01	500mm	4.0µm	10	50