

SERIES 328

SPLINE MICROMETER

- ◆ Measure grooves and sharpened parts
- ◆ Graduation: 0.01mm
- ◆ Carbide measuring faces
- ◆ Ratchet stop
- ◆ Setting standards are included (except 0-25mm)



328-001-01

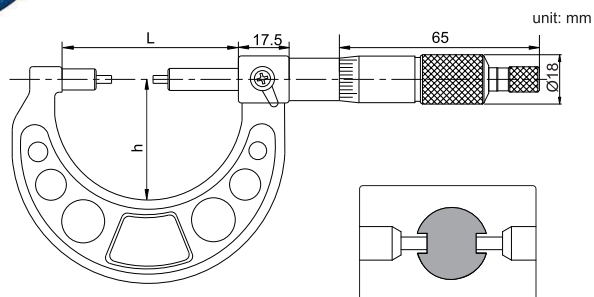

unit: mm

Code	Range	Anvil	Accuracy	h	L
328-001-02	0-25mm	A	4μm	39	58
328-001-01	0-25mm	B	4μm	39	58
328-002-01	25-50mm	B	4μm	53	83
328-003-01	50-75mm	B	5μm	65	109
328-004-01	75-100mm	B	5μm	76	133

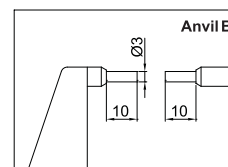
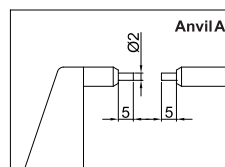

SERIES 341

TUBE MICROMETER

- ◆ Measure the wall thickness of tube, bearing and rings
- ◆ Graduation: 0.01mm
- ◆ Carbide measuring faces
- ◆ Ratchet stop
- ◆ Setting standards are included (except 0-25mm)



341-001-04

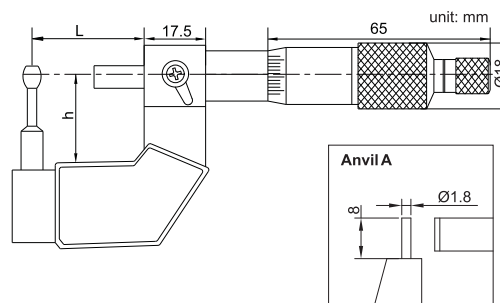

unit: mm

Code	Range	Anvil	Accuracy	h	L
341-001-01	0-25mm	A	6μm	24	31
341-002-01	25-50mm	A	6μm	32	57
341-001-02	0-25mm	B	6μm	24	31
341-002-02	25-50mm	B	6μm	32	57
341-001-03	0-25mm	C	6μm	24	31
341-001-04	0-25mm	D	6μm	24	31

